



Hangzhou PowerSonic Equipment Co., Ltd

A large graphic element consisting of a large, stylized letter 'A' shape. The left side of the 'A' is a light gray triangle containing an aerial photograph of a city skyline at sunset. The right side of the 'A' is a solid blue triangle. The text 'Product Brochure' is positioned to the right of the 'A' shape.

**Product
Brochure**



Hangzhou PowerSonic Equipment Co., Ltd

Export 20+ countries, Experience 10+ years

A Company Specialized In Ultrasonic Equipment

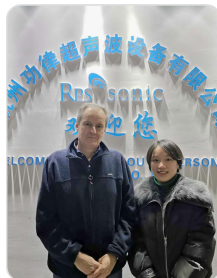
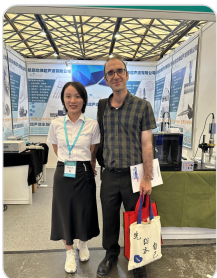

Famous Customers



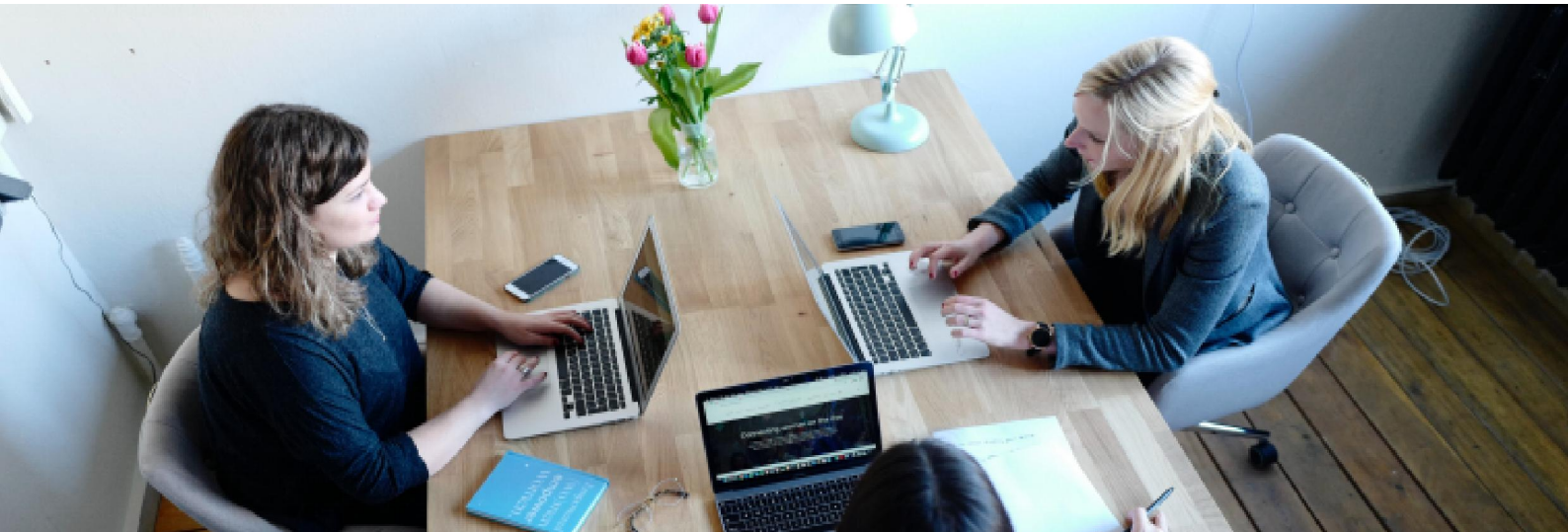

COMPANY PROFILE

About Us

RPS-SONIC is a technical company with perfect R & D, production, sales and service system, we have professional ultrasonic engineers and mechanical engineers and related technical personnel.

Ultrasonic products:

- Ultrasonic welding equipment (plastic welding, non-woven welding);
- Ultrasonic liquid processor (ultrasonic graphene dispersion, ultrasonic emulsification, ultrasonic mixing, ultrasonic extraction, ultrasonic homogenization);
- Ultrasonic cutting equipment (food cutting, non-woven cutting, plastic cutting, Rubber cutting), ultrasonic core components (transducers, amplitude transformer, horn);
- New ultrasonic applications: ultrasonic tinning, ultrasonic atomization, etc.



SGS



CE



ISO

★Free program consult&design

★One year warranty, Lifetime service

★Well sold worldwide

★Fast feedback before & after sales service

Ultrasonic Transducer



Ultrasonic transducer: The function of an ultrasonic transducer is to convert the input electrical power into mechanical power (i.e., high-frequency vibration) and transmit it out, while consuming very little of its own power. High-power ultrasonic transducers typically use a piezoelectric ceramic stack structure. For example: 20Khz ultrasonic transducer can vibrate 20000 times per second.

The composition of ultrasonic transducers: Ultrasonic transducers are mainly composed of a central piezoelectric ceramic element, front and rear metal cover plates, prestressed screws, electrode sheets, and insulation tubes.

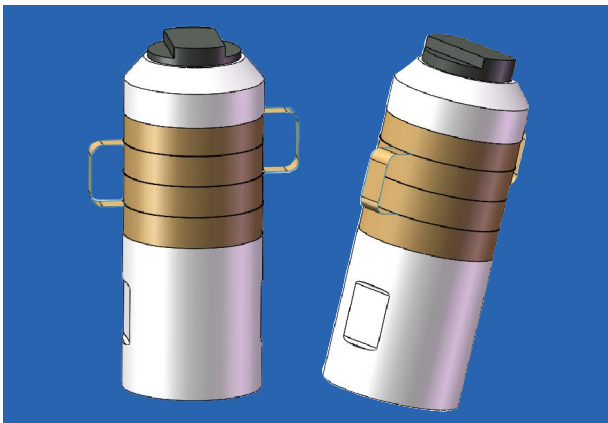

The principle and function of ultrasonic transducers: Ultrasonic transducers are piezoelectric ceramics resonating at ultrasonic frequencies. The piezoelectric effect of the material converts the electrical signal into mechanical vibration. Ultrasonic transducers are energy conversion devices that convert input electrical power into mechanical power.

Important parameters of transducers:

Frequency: determines the overall resonant frequency.

Amplitude: determines the output vibration amplitude.

Impedance: The impedance characteristics of the transducer should also match the impedance of the transmitter circuit to achieve optimal resonance.

Quality factor: It has an important influence on the waveform and response curve generated by the sensor during reception.

Capacitance: It is an important parameter for matching the generator.

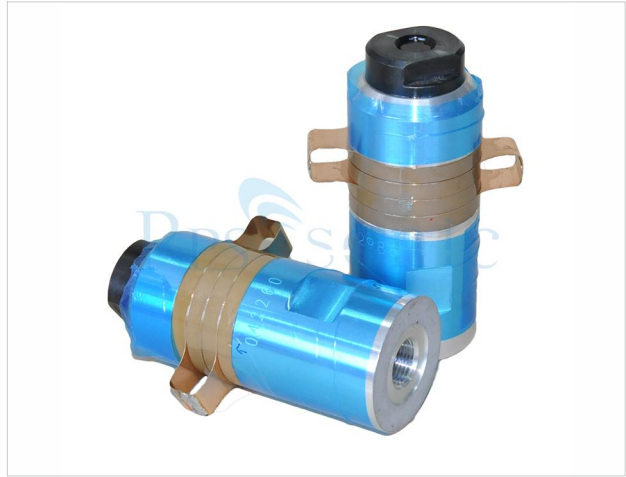

High performance
Good heat resistance



Traceable parameters
High surface finish



Best Piezoelectric ceramic material
Effectively reduces heat generation
Improves conversion efficiency
Extends service life

Structure Drawing

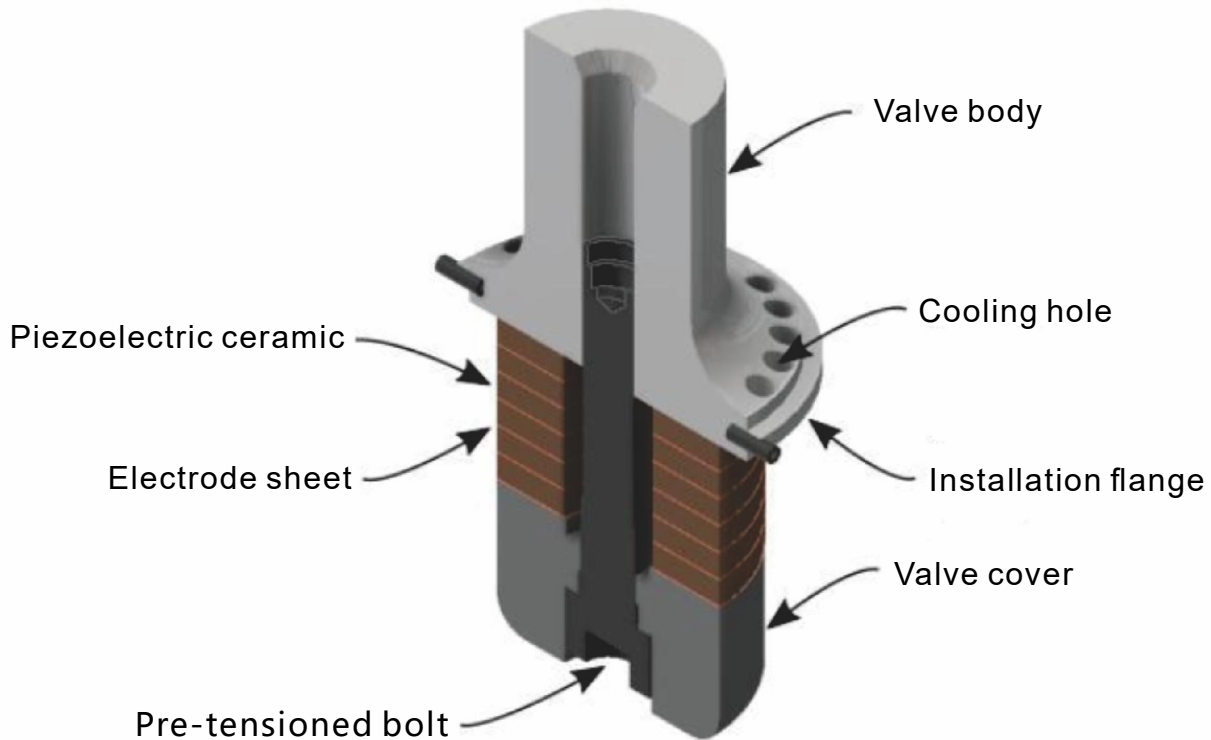

Product Parameter

Frequency: 15K-70Khz Available

Power: 100W- 5000W Available

Amplitude: 2 μ m - 20 μ m Available

Can customize depending on dimensions, frequencies, capacitance and other requirements, OEM services

Contact us for catalogue of the transducers. We have hundred types of ultrasonic transducers

Ultrasonic Welding Vibrator

Basic principle: Ultrasonic Welding Vibrator usually refers to the ultrasonic transducer + ultrasonic booster + ultrasonic horn. It is typically the most important and diversified component in ultrasonic welding system. It usually needs to be customized according to the shape of different ultrasonic welding parts. By matching the bottom mold, it achieves different shapes, patterns, and welding effects with different areas.



Excellent

Material excellent: High-quality steel or titanium and aluminum are used as the raw materials for the horn, to ensure the service life of the welding horn. Different materials for different applications, we will suggest optimal results.

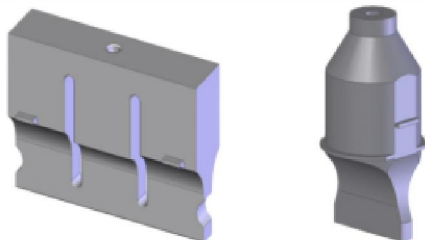

Strong

Strong output: Through professional software analysis, the resonant frequency of the oscillator is consistent to achieve maximum amplitude. Therefore, the output power is stronger, and the service life is longer.

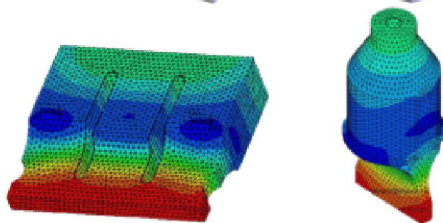

Stability

Well stability: The professional software design analysis and strict frequency testing and aging testing ensure that the ultrasonic oscillators received by customers are stable in output.

Ultrasonic Welding Vibrator

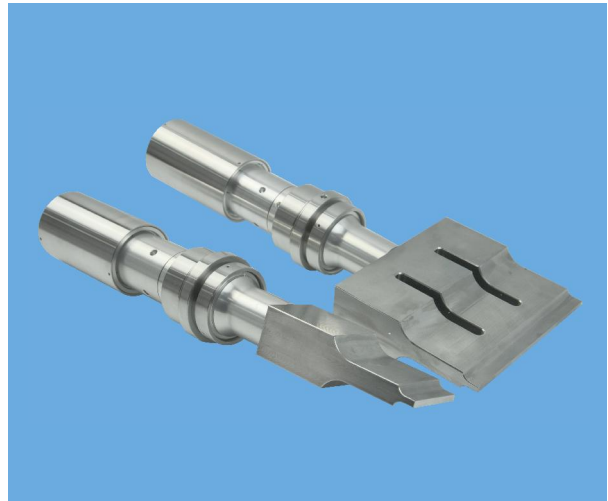

Product Parameter

Item	Parameter	
Frequency	15Khz	20Khz
Power	2600W	2000W
Dimension	less than 300mm	less than 250mm
The material of the horn	Steel , titanium , aluminum , select according to the application	

Ultrasonic spot welding gun

Handheld ultrasonic welding gun , also called ultrasonic spot welder, can be used for welding thermoplastic materials. According to different welding processes, the welding horn can be replaced for riveting, spot welding, embedding, cutting, etc. Ultrasonic welding is a fast, clean, and effective process used to assemble thermoplastic parts and some composite components. It is an advanced manufacturing and assembly technology.



Advantages of Ultrasonic spot welding gun

- ◆Can be used for plastic riveting, cutting, stitching, welding , etc. ;
- ◆The machine avoideds the defects of traditional hot welding machines, such as yellowing, burning edges, and excessive thickness;
- ◆Easy and fast to operate, with a built-in automatic protection circuit for safe use, smooth and reliable operation;
- ◆High-quality components are selected for assembly, and the compact design makes the machine easy to move and use;
- ◆The output is strong and the welding quality is stable, with reliable performance indicators and low failure rate;
- ◆Eliminates the pinhole phenomenon caused by traditional sewing;
- ◆Uses vibration friction or cutting, no smoke, no strange burnt, and no danger of high-frequency radiation or thermal cutting machines, and no environmental pollution;
- ◆Can be started for production and processing without preheating, with easy operation and faster, more efficient and low labor cost continuous production and processing;
- ◆Supports customized ultrasonic horn, easy to replace, and suitable for various different application.

Product Pictures



Handheld Spot Welding Gun



Straight Grip Spot Welding Gun

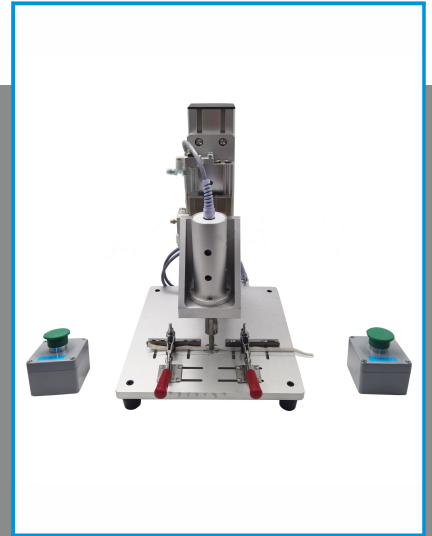

Desktop Spot Welding Gun

/ Product Packing /



Portable Suitcase Packaging

Obtained EU CE Certification

Multiple Configurations Available

Exquisite Packaging
Fast Delivery

Parts Of Product



Multiple horns can be selected

Supports customization

Supports personalized design

Supports sample testing



Application

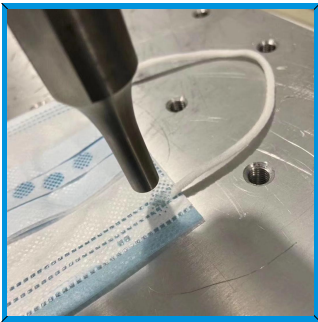

Medical Industry



Electrical Appliances



Sound Insulation Cotton Welding

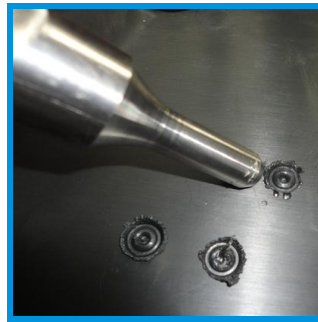

Automotive Parts Welding

Product Parameter

Item	RPS-HW35	RPS-HW28	RPS-HW20
Frequency	35Khz	28Khz	20Khz
Power	500W	600W	800W
Power source	Digital generator 2000E or 2000B		
Materials	Customized from 2mm to 10mm, titanium or aluminum		
Appearance	Straight grip or pistol, with a handle in 1kg, convenient for operation		

Ultrasonic Sewing Welding

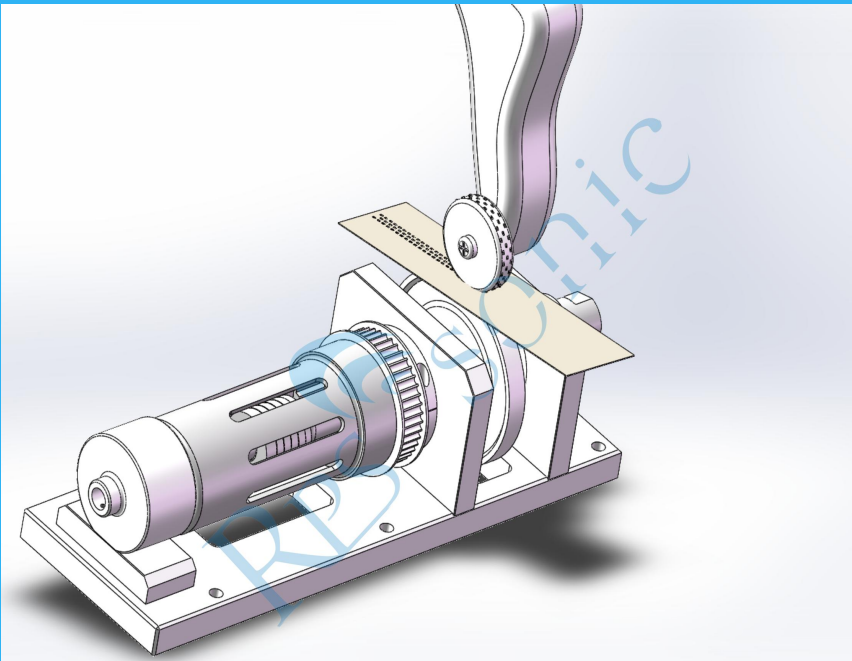

Use high-frequency oscillation transmitted to the working material welding surface by the welding horn to instantly create friction between the molecules of the working material, reaching the melting point of the plastic and completing the welding process by rapidly dissolving the solid material.

Using an ultrasonic sewing machine for stitching, no need needles and threads, avoiding the trouble of frequently changing needles and threads. There are no traditional thread sewing broken joints, and it can also achieve neat local cutting and sealing of textiles. At the same time, it also plays a decorative role, with strong adhesion, waterproof effect, clear embossing, and a more three-dimensional relief effect on the surface. It works quickly and has high-end and beautiful product effects, with better quality.

Sewing Machine Welding Demonstration

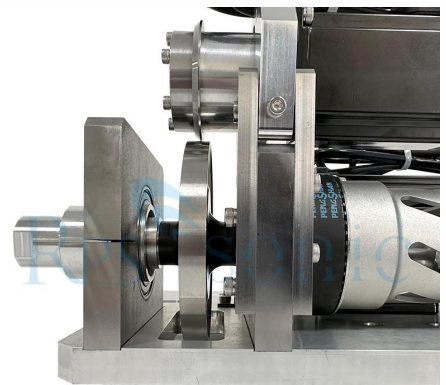
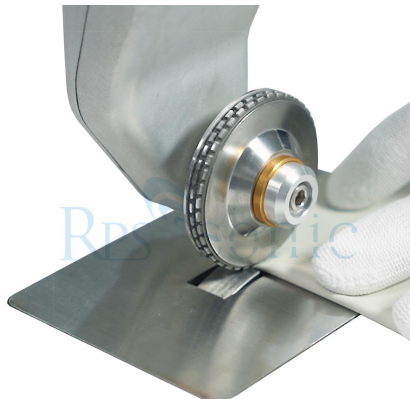
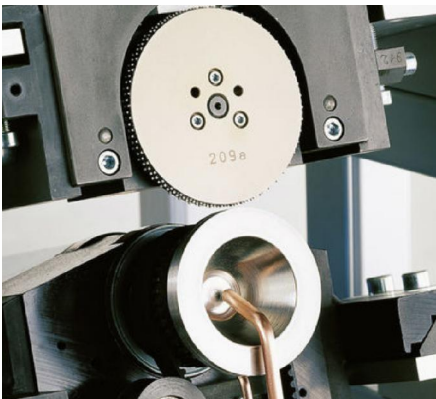

Ultrasonic Sewing Machine

01 Ultrasonic Sewing Machine

Ultrasonic rotary sewing installed in a bearing seat, which can be installed in any direction. There are 20 and 35 kHz selected, and a disc width of 11.5 & 15mm is optional. The machine is suitable for mechanical manufacturers who want to develop their own production lines and experienced end users. The operation of the ultrasonic sewing machine is similar to the traditional rotating sewing machine, but it produces a soft, smooth, and waterproof welding effect. When combined with a roller, different sewing patterns can be produced, and waterproof is also ok.



02 Desktop Sewing Machine

The independent table makes welding flexible and tight, and provides an unobstructed fabric view in the processing area. Two foot switches are easy to operate: the first foot pedal can lift and engage the turntable to apply force to the processed material; the second foot pedal can start the ultrasonic and wheel rotate, and the operator can adjust the speed.

Designed for the safety of operators: there are no needles and other dangerous parts left on the work surface above the workbench, and there is a touch screen panel that can adjust the welding speed.



03 Two-in-one Sewing Machine

The combination ultrasonic rotary sewing, such as single or multiple sets of ultrasonic rotary sewing, ultrasonic generators, motors, mounting bases, operating programs, and touch screens. It can be directly installed on the corresponding material conveying ribbon to achieve a streamlined production line. If there are multiple sets of ultrasonic rotary sewing machine, multiple welding line can be welded at the same time. The touch screen can adjust the welding speed and synchronize with the material production line to achieve seamless connection.

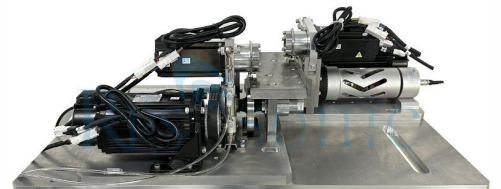

Accessories Of Ultrasonic Sewing Machine



Multiple options for sewing horn and rotary sewing!

Parameter

Item	RPS-R20	RPS-R35
Frequency	20Khz	35Khz
Power	1000W	800W
Welding width	Maximum 15mm	
Welding tool head	20kHz radial wave	35kHz radial wave
Welding method	Continuous welding	

Automatic Ultrasonic Welding System

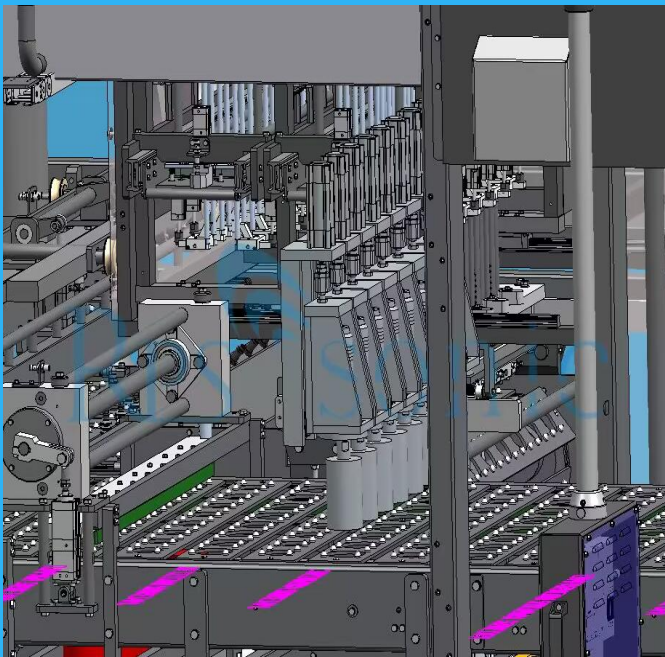

With the rapid development of the material industry, the application of plastic materials has been widely recognized. Plastic products have penetrated into various fields of people's daily lives. However, due to the limitations of injection molding processes and other factors, the traditional process is not only inefficient but also the adhesives used have some toxicity. It cannot meet the development needs of modern plastic industry. Ultrasonic plastic welding has emerged with its advantages of high efficiency, high quality, beautiful appearance, and energy-saving.

Automated ultrasonic welding systems different from traditional ultrasonic welding machines.No fixed base and are suitable for installation in automated production lines. They have a compact design , combined with automated programs, can achieve efficient welding.

Provide Design Of 2d & 3d Graphics:

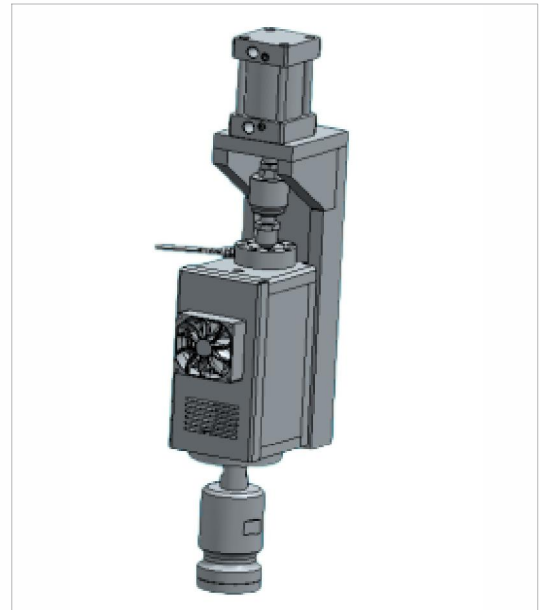
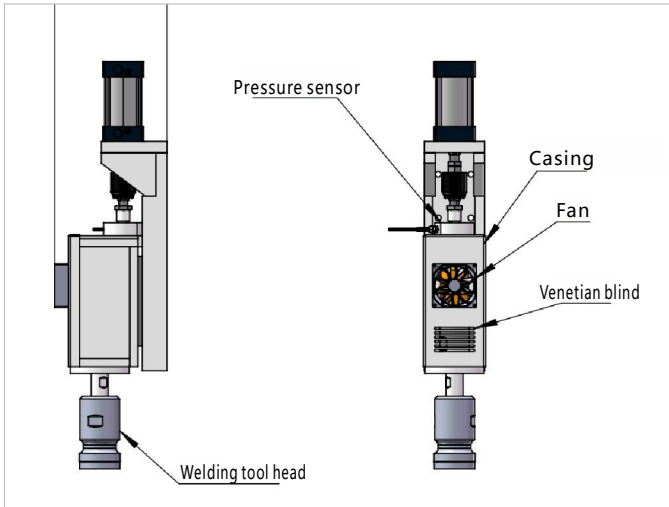

Welding horn of beverage cup lid

The principle of ultrasonic plastic welding: a 20KHZ high-frequency signal is generated by the generator, and the signal is converted into high-frequency mechanical vibration through the transducer, which is applied to the plastic product workpiece. The workpiece welding interface is rapidly melted through the friction between the working surface and the internal molecules. Then, it is filled into the gap between the interfaces. When the vibration stops, the workpiece cools and solidifies under a certain pressure, achieving a perfect welding effect.

The beverage cup lid is the most typical and common application of ultrasonic welding in a streamlined production line. We can also apply it to various plastic production lines, providing personalized design and program services.

Product Parameter

Item	RPS-AUTO-W20	RPS-W series
Frequency	20Khz	15-35Khz
Power	2000W	800-3200W
Power source	AC 220V/50Hz	AC 220V/50Hz
Application	Ultrasonic welding production line	Ultrasonic welding

Ultrasonic Cutting Knife

Working Principle :

The basic components of the ultrasonic cutting knife are an ultrasonic generator, booster, and a cutting knife. Ultrasonic cutting is a process with high frequency vibrate. Applying ultrasonic vibrations for cutting can produce a nearly frictionless cutting surface, which brings many benefits. This low-friction cutting surface can cleanly and neatly cut ,without any mess. Additionally, it greatly reduces cutting resistance, making cutting easier and smoother. At the same time, the high-frequency vibration friction causes the material to melt and fuse together, resulting in no burrs or flying debris. Therefore, ultrasonic cutting knives are widely used in food cutting, plastic cutting, medical equipment cutting, and fabric cutting.



Rubber/food Cutting Knife



Food Cutting Knife

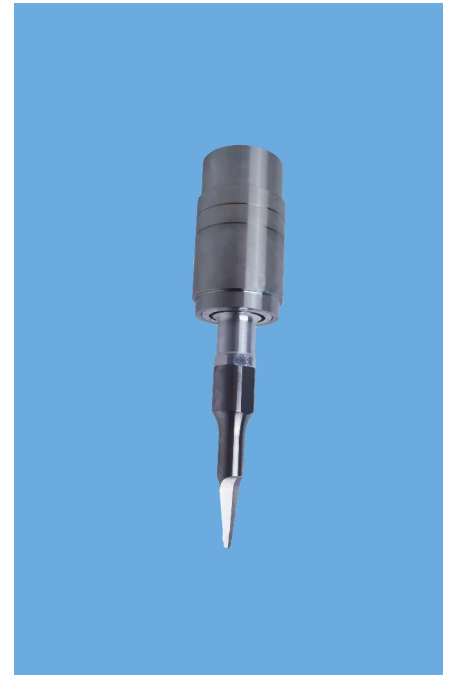

Machine Mounted Cutting Knife



computer control
ultrasonic food cutting knife

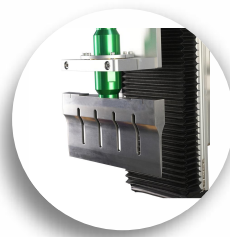

Titanium Blade



Computer Control

Advantage:

- 1. Non-Pollution, with no smoke, odor, or flying debris produced during cutting, eliminating dust and air pollution during cutting;
- 2. Reduce waste, as it does not crush or damage your products during cutting, reducing waste;
- 3. Ensure neat, smooth, and non-deformed incisions, enhancing the appearance and value of the product. (Providing a good cutting surface);
- 4. Reduce stop time, as the blades do not need to be cleaned frequently when cutting sticky products;
- 5. The blade is made of durable titanium material;
- 6. Reduce cutting resistance, cutting faster.

Machine-mounted Ultrasonic Cutting Knife



It is often used for food cutting, which is clean and hygienic, with neat and beautiful cutting surfaces, and can also avoid unnecessary waste.

Components Of Ultrasonic Cutting Knife

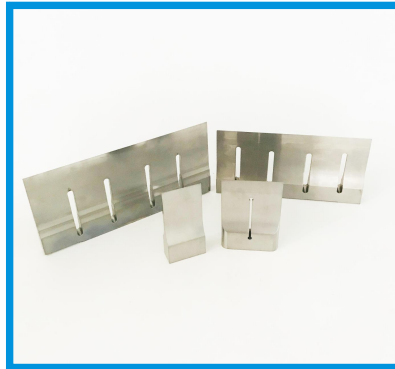

Application

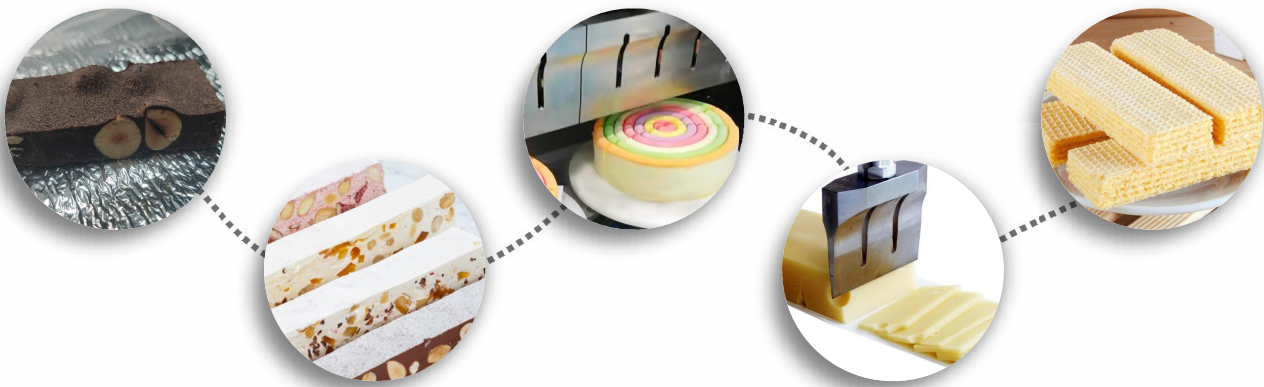

Product Parameter

Item	RPS-PC40	RPS-PC20
Frequency	40Khz	20Khz
Power	500W	1000W
Width	82.5mm	50,100,150,200,255,305mm
Generator	2000C or 2000E digital generator	
Materials	Titanium	
Height	60mm	120mm

Ultrasonic Plastic/nonwoven Fabric Cutter



35k Slicing Machine



35k Nonwoven Fabric Sealing And Cutting Machine



35k Handheld Sealing And Cutting Machine

Product Accessories



KNIFE

The blades are replaceable, which extends the service life of the entire machine.

SECURE

Safe and environmentally friendly, using high-frequency vibration for cutting.

EASY

Easy to cut, Switching between manual and machine-mounted.

Application Fields

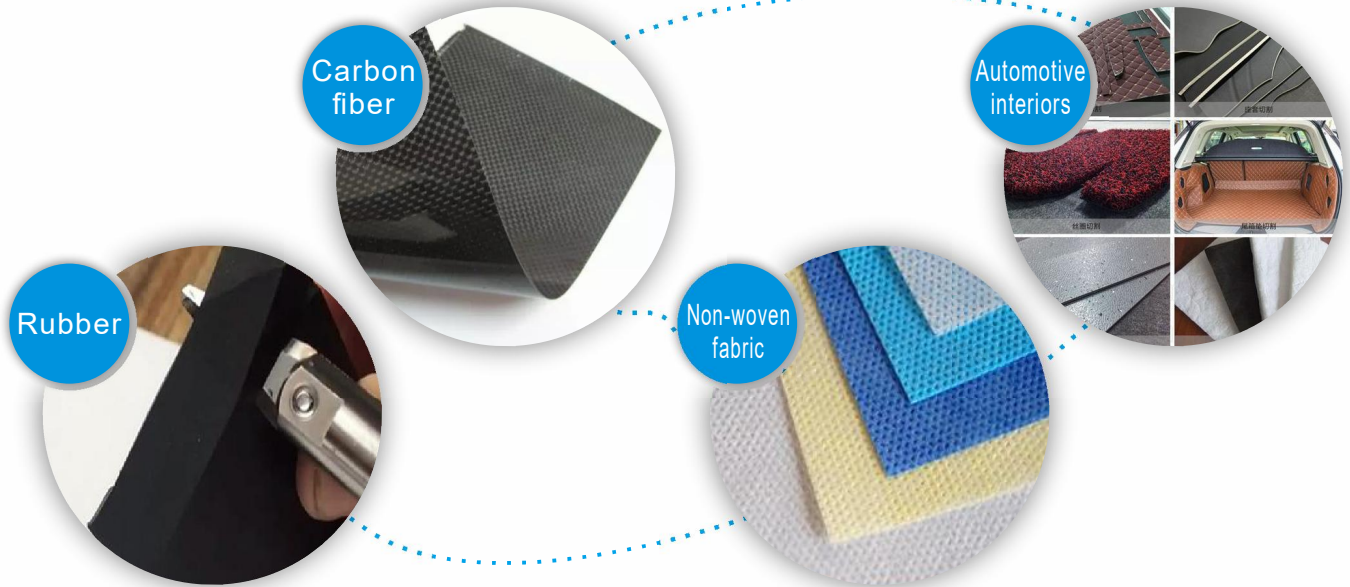

Ultrasonic cutting uses the energy of ultrasonic waves to heat and melt the material to be cut. There is no need for sharp edges or large pressures, and it can easily cut rubber, plastic, carbon fiber, PP, PE, non-woven fabric, film, and various overlapping composite materials.

Product Parameter

Item	RPS-PC20	RPS-PC30	RPS-PC40
Frequency	20Khz	30Khz	40Khz
Blade type	Threaded	Forceps holder	Integrated
Amplitude	40μm	20μm	20μm
Power	500W	300W	300W
Blade length	15mm	25mm	55mm
Generator	2000E or 2000C		

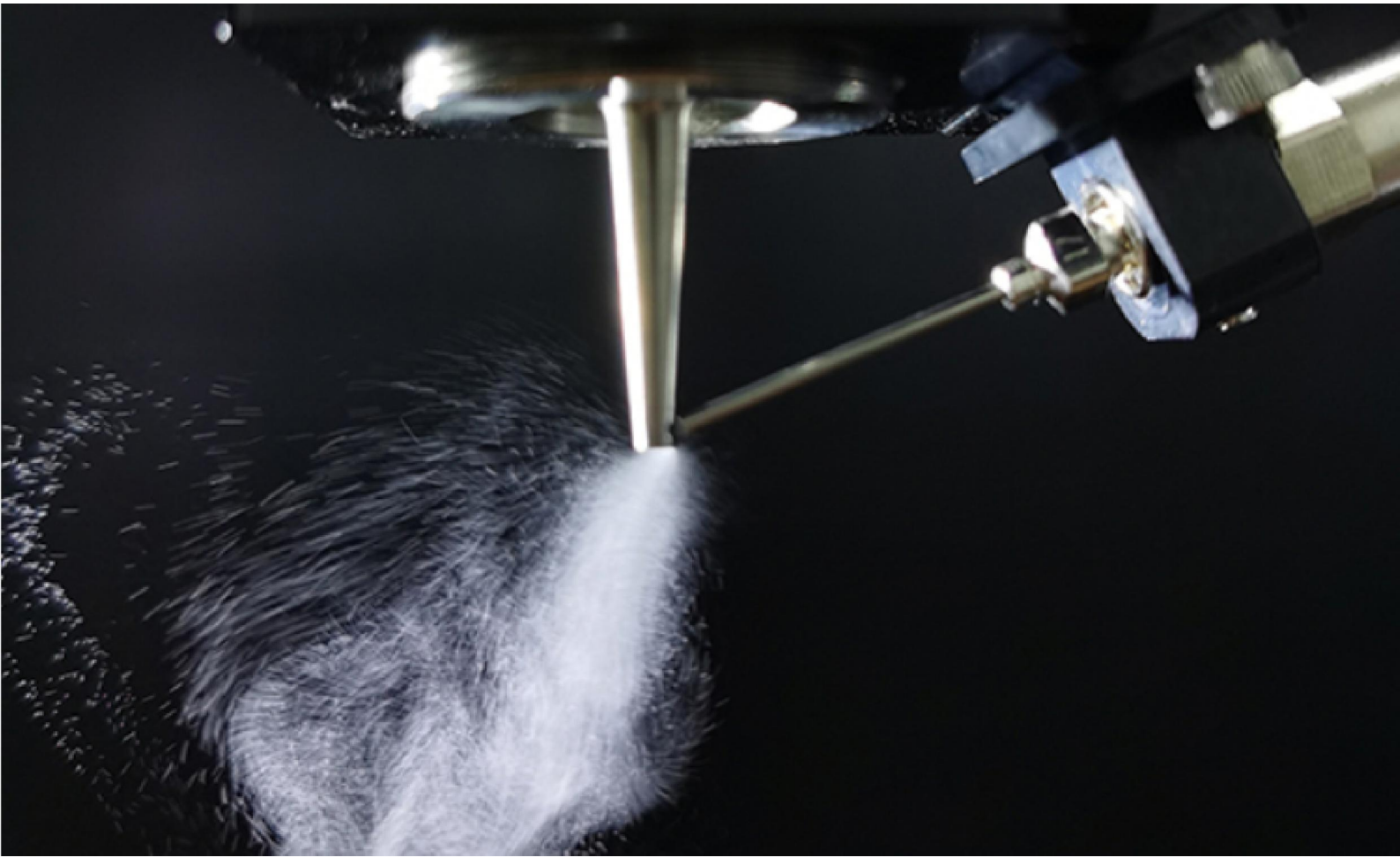

Ultrasonic Atomization

The principle of ultrasonic atomization involves three basic steps: the propagation of ultrasonic kinetic energy, the expansion of ultrasonic kinetic energy, and the nucleation and refinement of droplets. Firstly, the sound energy propagates from the ultrasonic generator to the ultrasonic atomization container in the form of ultrasonic waves, causing sound pressure fluctuations. Secondly, due to the change in internal pressure, the liquid expands under pressure, producing vortices. Finally, under the action of vortices, the liquid is forced to be extruded and forms droplets, which are then broken and cross-linked multiple times, resulting in gradually refined and small droplets.

Applications: Ultrasonic spray technology can be used to deposit uniform nano-coatings on substrates of any width. Ultrasonic spray technology enables these very thin coatings to be produced with extremely high uniformity, even in a very wide range, for unique nano applications. Ultrasonic nanomaterial coating systems are uniquely suited to spraying nanosuspensions like CNTs, nanowires, perovskite, graphene, and others.

www.rps-sonic.com / www.sono-liquid.com

Ultrasonic Atomization Nozzles



Ultrasonic transducer convert high-frequency signals into mechanical energy. As the liquid leaves the atomization surface of the nozzle, it is broken into uniform micro-sized droplets. This is different from traditional nozzles which rely on pressure and high-speed movement . Ultrasonic nozzles use high-frequency vibrations to atomize the liquid, with low energy consumption and minimal waste. The liquid can be delivered to the nozzle by its own weight or a low-pressure liquid pump for continuous or intermittent atomization.

Non-clogging spray

Unlike pressure nozzles, ultrasonic nozzles do not need small holes to generate pressure. The liquid is fed into the nozzle center via a larger hole without pressure, and is atomized by the ultrasonic vibration in the nozzle. The liquid supply channel and hole in the nozzle are relatively large, achieving non-clogging spraying.

More stable spraying

Ultrasonic spraying systems can be integrated with automated equipment for stable spraying coating, with particle sizes ranging from 25um to 50um.

Anti-pollution

The nozzle is made of high-strength titanium alloy and other proprietary metals, making it highly resistant to chemical corrosion and having excellent acoustic performance. The electrical components are contained in a sealed housing that protects the nozzle assembly from external pollution. .

Application fields

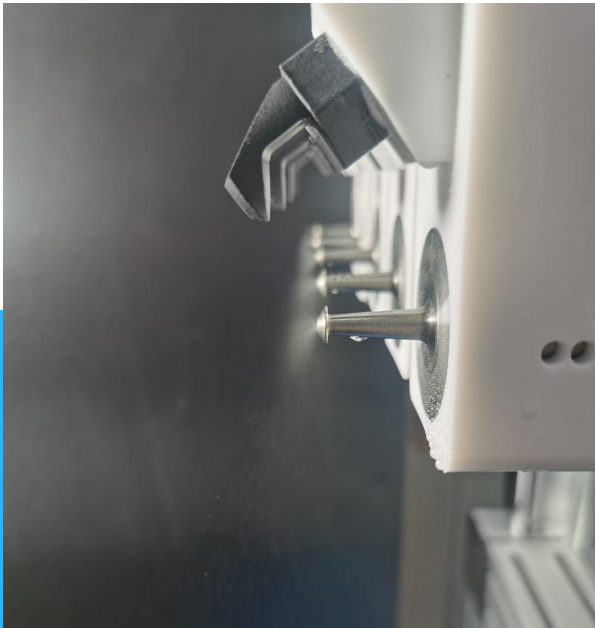

Ultrasonic atomization spraying systems are now widely used in many fields, mainly in energy and nanomaterials, electronics, medical equipment, glass coating, and industrial sectors.

Alternative energy and nanomaterials: Ultrasonic fuel cell catalyst coating system, electrolytic tank coating system, perovskite solar cell coating, carbon nanotubes, nanowires and other nanomaterial coating systems, spray pyrolysis and TCO coating systems.

Electronics: Ultrasonic soldering flux spray system, ultrasonic selective melting system, spray-plastic photoresist coating system for semiconductor lithography, packaging-level electromagnetic interference shielding protective coating.

Medical equipment: Coating systems for medical diagnostic equipment and reagents, coating systems for blood collection tubes/injector tubes, ultrasonic and antibacterial coating systems for bandages and infection protection, ultrasonic nozzles for biological aerosols, cell biology, and immunological research.

Glass and industrial: Anti-fouling float glass coating system, functional glass coating for thin film, hard coating and other thin film protective glass coating, protection and functional coating for lens coating system,.

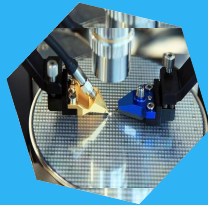
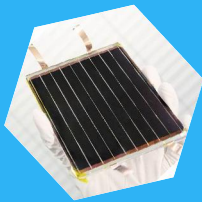

Item	Wide type	Diffuse type	Bunching type	Long nozzle type	External fluid supply
Diameter of atomized particle	15-40	15-41	15-42	15-20	15-20
Spray width (μm)	40-120	40-80	2-20	1-3	0.5-2
Spray height (μm)	50-150	30-80	10-30	10-20	10-20
Flow (ml/min)	0.5-20	0.5-20	0.5-10	0.5-10	0.01-1
Suitable viscosity (cps)	< 30	< 30	< 30	< 15	< 15
Particle size in liquid (μm)	< 20	< 15	< 10	< 8	< 8
Diversion pressure (mpa)	< 0.05	< 0.05	< 0.05	/	/

The above reference is obtained by testing pure water at normal temperature and pressure.

Sonochemistry

Sonochemistry is the application of ultrasound to chemical reactions and processes. Sonication is used to intensify chemical reactions such as synthesis and catalysis. When intense ultrasound waves are coupled into liquids, the phenomenon of acoustic cavitation occurs. Ultrasonic cavitation improves mass transfer between reactants, speeds up the reaction and/or allows to change the chemical pathway.

Sonochemistry also known as sonicator, ultrasonic homogenizer, ultrasonic liquid processor.

Ultrasonic homogenizers are powerful tools to mix and homogenize solid-liquid and liquid-liquid suspensions. Ultrasonic homogenization is a mechanical process to reduce particles in a liquid so that they become uniformly small and evenly distributed. RPS-SONIC offers powerful ultrasonic homogenizers for application in lab and production scale.

Ultrasonic homogenizers are powerful and reliable mixers for lab and industry for numerous applications. An ultrasonic homogenizer can be used for various applications, including:

Homogenization: Ultrasonic homogenizers can homogenize samples to create uniform and consistent mixtures. **Dispersion:** Ultrasonic homogenizers can be used to disperse solid particles in liquids to create stable suspensions, to get nano-dispersions. **Emulsification:** Ultrasonic homogenizers can be used to create stable emulsions and nanoemulsions by breaking up and dispersing immiscible liquids, such as oil and water. **Cell Disruption:** Ultrasonic homogenizers can break open cells to extract intracellular components. **Degassing:** Ultrasonic homogenizers can be used to remove dissolved gases from liquids. Anti-scaling and descaling, sterilizing, extraction Etc.

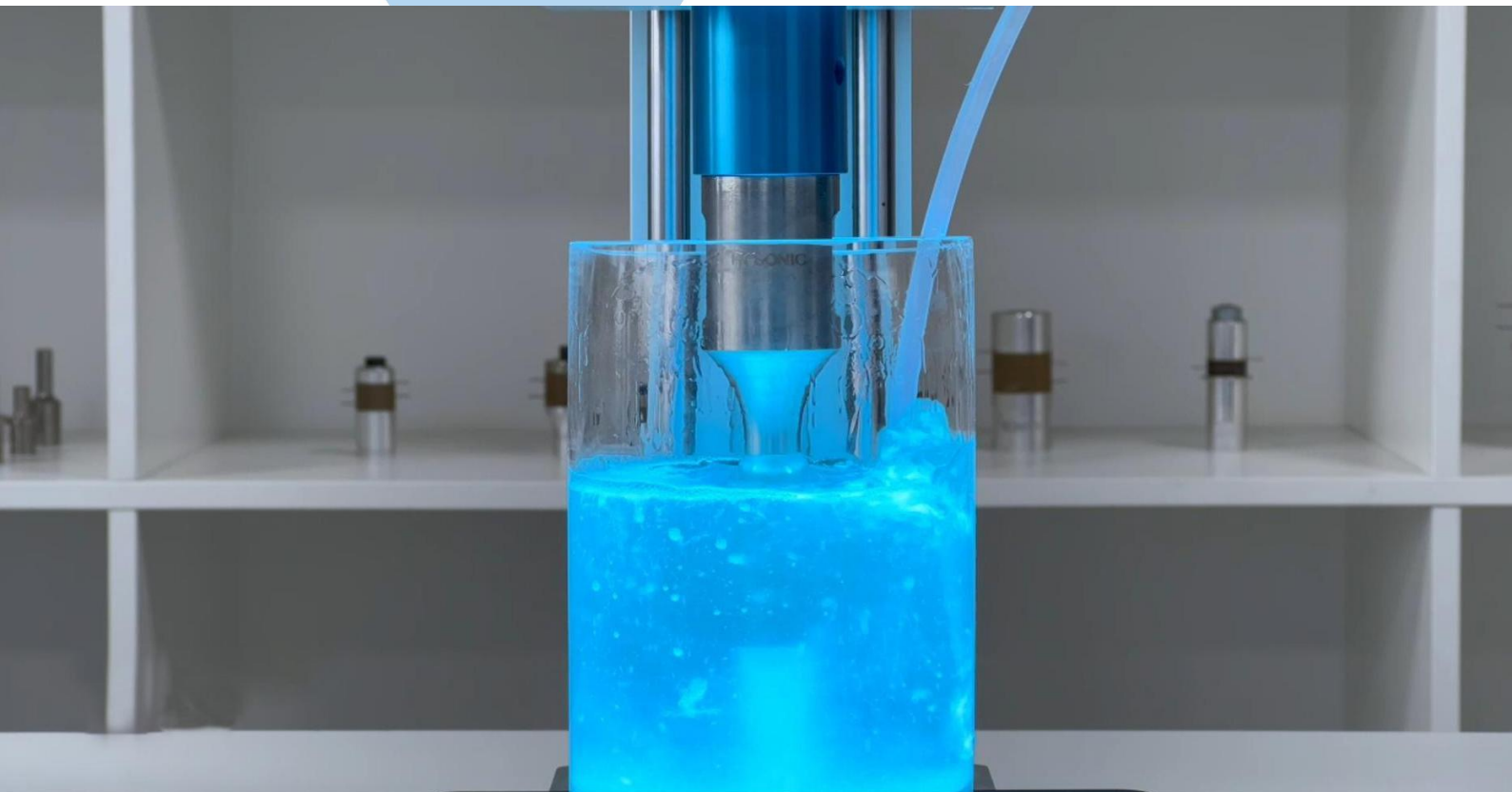

Types Of Sonochemistry Equipment ▶▶▶▶▶▶▶



Explosion-proof Ultrasonic Sonochemistry Equipment



Ultrasonic Nano-emulsion Equipment



300w Constant Temperature Sonicator



Ultrasonic Metal Aluminum Melt Treatment Equipment



Ultrasonic Homogenization And Descaling Equipment



4 In1 Ultrasonic Emulsifying And Dispersing Equipment



3 In1 Ultrasonic Dispersing Equipment



Ultrasonic Liquid Processing Pilot Plant



Ultrasonic Graphene Production Equipment

Advantage Of Ultrasonic Sonochemistry

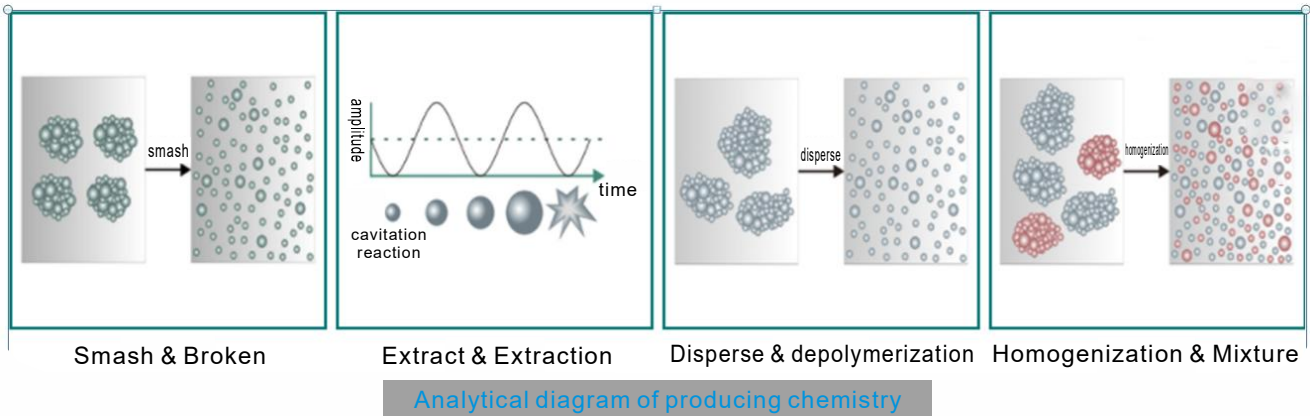

1. Ultrasonic technology in higher efficiency .
2. Ultrasonic technology does not require high temperature or pressure, safety and easy to operate and maintain.
3. Ultrasonic technology can be used to process most liquids.
4. In most cases, ultrasonic equipment has fewer operation steps, a simple process, low temperature, and is suitable for the operation of heat-sensitive components. It is less likely to cause pollution.
5. Ultrasonic equipment improved extraction(emulsify) rate and save raw materials , save production cost, and has significant comprehensive economic benefits.



Professional Designers And Related Technical Personnel

Provide Reliable Service

- Free technical consultation
- Company support for technical exchanges
- Sample test free

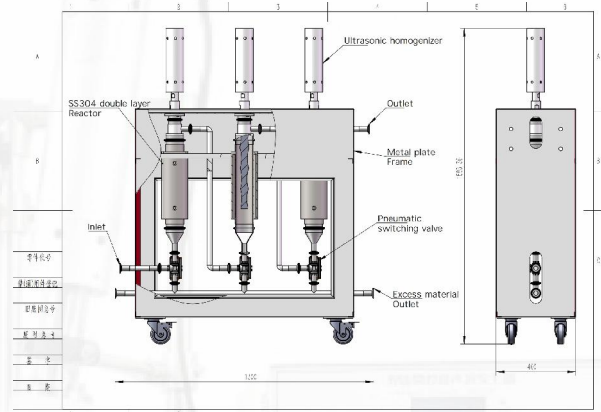
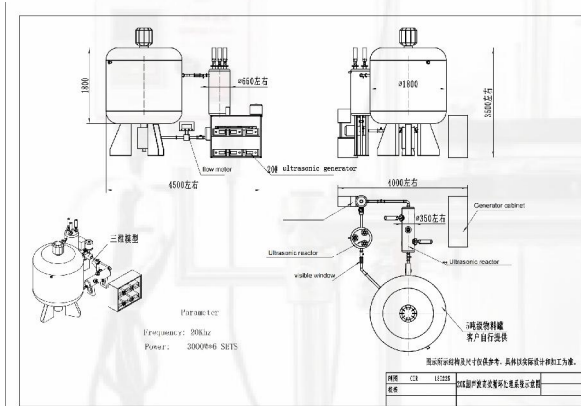

- Program design free
- Customized solutions depending on customer's application
- Pursuing the highest efficiency of chemical processes, simplifying modification, and providing economical solutions.

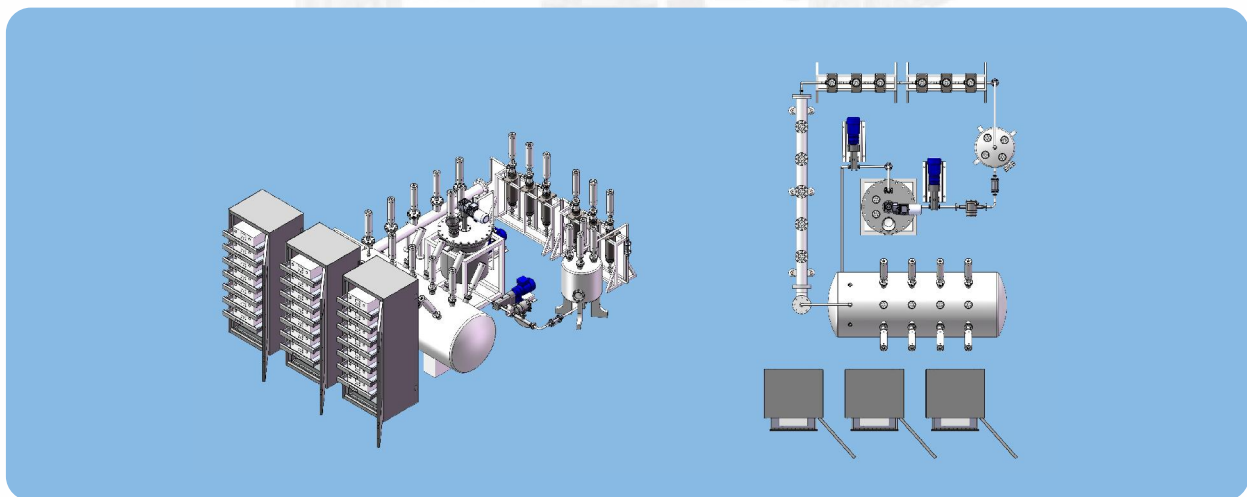

3D Models

Product 3D Drawing

Technical Personnel

- Our company has professional mechanical engineers in ultrasonic fields, and related technical personnel.
- We will provide reliable services for users in any stage of pre-sale, in-sale, and after-sale.
- We will help users maximize the effectiveness of their ultrasonic equipment during use, and provide 24-hour full-service support.

Product Parameter >>>>>>

Industrial Grade Parameter

Item	Sono-20-1000	Sono-20-2000	Sono-20-3000	Sono-15-3000
Frequency	20±0.5Khz	20±0.5Khz	20±0.5Khz	15±0.5Khz
Power	1000W	2000W	3000W	3000W
Voltage	220V			
Maximum temperature	300°C			
Maximum pressure	35Mpa			
Intensity of sound	20W/cm ²	40W/cm ²	60W/cm ²	60W/cm ²
Handling capacity	10L/min	15L/min	20L/min	20L/min
Materials of probe	Titanium alloy			

Laboratory Grade Parameter

Item	Sono-L20	Sono-L28	Sono-L40
Frequency	20Khz	28Khz	40Khz
Power	1000W	800W	500W
Maximum capacity	5L	2L	1L
Maximum temperature	300°C		
Materials of probe	Titanium alloy		

Ultrasonic Tinning Machine

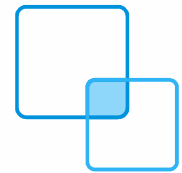

Ultrasonic tinning is a soldering method that does not use flux. The ultrasonic probe generates cavitation in the molten solder core through mechanical vibration at ultrasonic frequency, removing the oxide film on the metal surface and achieving a smooth and clean tin plating.

Ultrasonic tinning is a flux-free connection method that uses high-frequency mechanical vibration instead of flux. The size of the ultrasonic tin furnace can be customized according to the size of the customer's welding material. It can also be modified based on the customer's existing tin furnace, using ultrasonic technology to replace flux, achieving environmentally friendly plating.



Features:

▲ A green and environmentally friendly soldering solution:

It does not emit any harmful chemicals to the environment and the human. There is no need for flux.

No water & air pollution. When soldering, no flux is used, and there is no emission of harmful gases or industrial wastewater.

▲ Achieving perfect tinning:

Tinning without flux - no welding defects caused by the strong corrosion of flux. The ultrasonic vibration allows the solder to penetrate small gaps, making the solder joint firm and reliable.

▲ Cost-saving, more efficient, and safer:

No flux needed, so users can save time and cost in cleaning up residual flux, also reducing corrosion and increasing the durability of the solder joint. Tin-lead solder is usually used for metals that are easy to wet, such as silver, copper, and nickel. Tin-silver solder is used for stainless steel, while tin-zinc and zinc-aluminum alloys are used for aluminum. Indium alloys are often used for glass and ceramics.



Product Application And Parameters



Application:

- Tinning of electronic components (flux-free);
- Tinning of aluminum (or copper) magnetic wire electronic components such as motors, transformers, and inductors;
- Other special soldering (flux-free);
- Soldering of other non-ferrous metal products that are difficult to weld (aluminum, nickel, molybdenum, copper, glass, ceramics, other non-ferrous metals).

Item	Parameter
Frequency	20Khz
Amplitude	12-20 μ m
Heating power	1000W
Ultrasonic power	300W
Work time	24-hour continuous operation
Coating materials	Copper, glass, aluminum, ceramics, etc.
Solder materials	Tin, indium, and other solders with a melting point below 700 $^{\circ}$ c.

Choose RPS-SONIC

Win-Win Cooperation



Whatsapp

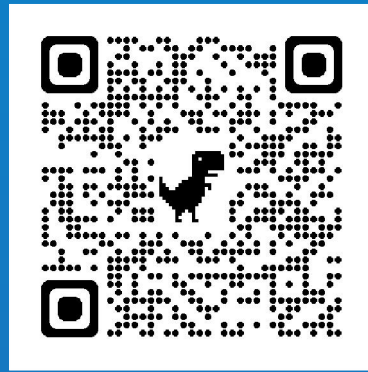

Website

RPS-SONIC is always your reliable supplier

TEL: 86-571-63481280

E-MAIL: admin@rps-sonic.com

Address: Enbo Road No. 1028, Xinxing Pipe Casting Park,
Fuyang District, Hangzhou City, Zhejiang Province.